

**HD** **50Hz**  
SERIES

SUBMERSIBLE DEWATERING PUMPS



HD 1.5HP



HD 2~5HP



HD 7.5~10HP



HD 15~20HP



ADTC

# HD

## FEATURES

- Compact, robust and easy handling for all construction and civil engineering dewatering application conditions.
- Stainless steel (SUS304) outer casing, the self-cooling motor is suitable for continuous duty and low water level conditions.
- Standard accessories include the cable with an epoxy resin sealed water-resistant cable base, Auto-cut motor protector, double mechanical seals, oil seal design, and High Solid Epoxy coating.
- High efficient special impeller design in High Chrome Alloy steel (HiCrFC), with a hardness of 55 - 60 Rockwell, to stand high abrasive applications.
- The pump internal castings are all protected by the high solids epoxy coating, which can prolong the metal life and avoid corrosion and oxidation.
- The mechanical seal bracket is covered by EPDM with anti-abrasive wear for HD 15~20HP models.
- Optional ADTC (Adapter Connection) Casing to connect suction with inline pipe, allowing surface/inline/deep well pumping.



Open Impeller



Close Impeller

## APPLICATIONS

- Civil engineering, dewatering, tunneling, groundworks, mining, and manhole sewer.
- Industrial wastewater dewatering of fluids containing solid sediments.
- Portable use for contractors, installers, and industry.

## PRODUCT NOMENCLATURE

100	HD	2	5.5
Discharge mm	Type	Pole	kW

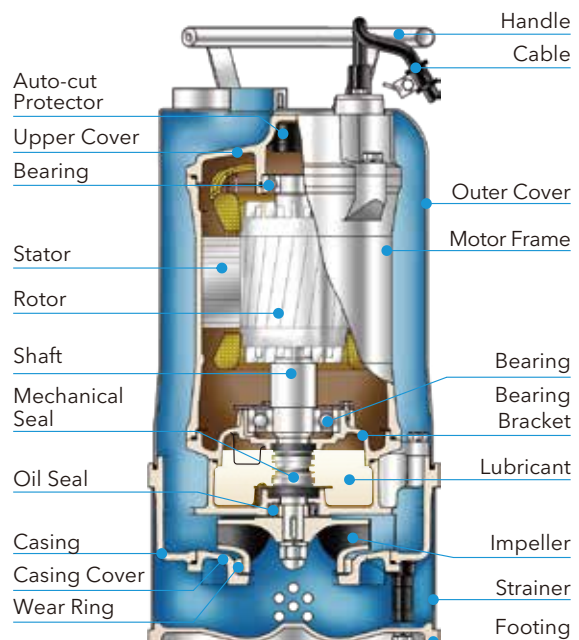

# HD

## SUBMERSIBLE DEWATERING PUMPS



### PERFORMANCE CURVES

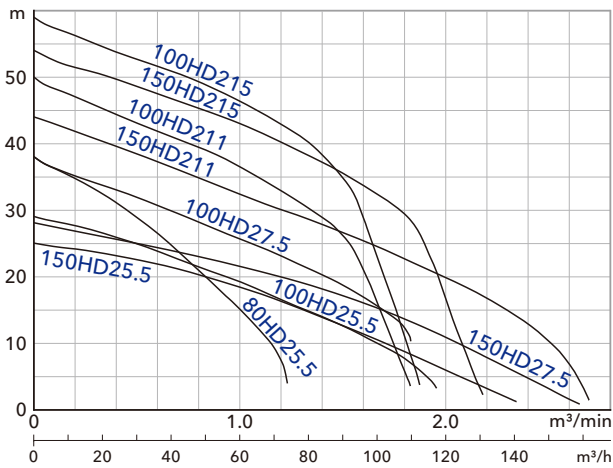
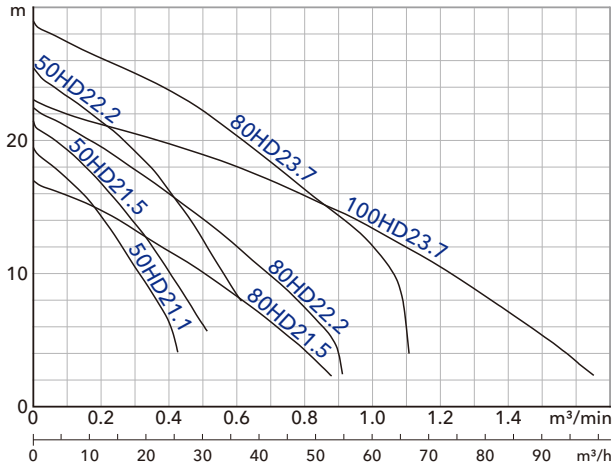

### SPECIFICATIONS

Item		Description
Limits of Use	Liquid Temp.	0~40°C (32~104°F)
	Applications	Construction sites • Basins dewatering
Type	Frequency	50Hz
	Motor	2P (3000rpm) • Dry Motor
	Insulation	Class F (1.5~5HP) • Class H (7.5~20HP)
	Protection	IP68
	Protector	Auto-cut
	Bearing	Ball type
	M.seal	Double M.seals
Material	Impeller	Open • Close
	Outer Cover	SUS304 / X5CrNi18-10
	Upper Cover	FC200 / GG-20
	Motor Frame	SUS304 / X5CrNi18-10 (1.5HP) • FC200 / GG-20 (2~20HP)
	Shaft	SUS403 / X5Cr13 (1.5~3HP) • SUS304 / X5CrNi18-10 (5~10HP) • SUS420J2 / X30Cr13 (15~20HP)
	M.seal	CA/CE & SiC/SiC
	Casing	FC200 / GG-20 (1.5~10HP) • FCD500 / GGG-50 (15~20HP)
	Impeller	HiCrFC
	Wear plate	HiCrFC (For Open)
	Wear ring	HiCrFC (For Close)
	Cable	VCT or H07RN-F
Optional	Pumps can be customized to fit specifications Floating Switch (1.5~3HP 1Ø)	

### PERFORMANCE SPECS.

※ Note : Weight Without Cable & Outlet.

Model	Output HP(kW)	Discharge Inch(mm)	Phase Ø	Start Method	Head m	Standard		Solid Passage mm	Weight kg		Dimensions mm					
						m³/min	m³/h		1Ø	3Ø	A	B	3Ø	1Ø	C	3Ø
50HD21.1	1.5(1.1)	2"(50)	1/3	Capacitor DOL	13.5	0.2	12	7.5	28	24	210	482	423	431	372	
50HD21.5	2(1.5)	2"(50)	1/3	Capacitor DOL	15	0.25	15	10	40	36	235	511	466	463	418	
50HD22.2	3(2.2)	2"(50)	1/3	Capacitor DOL	19	0.3	18	10	44	39	235	541	466	463	418	
80HD21.5	2(1.5)	3"(80)	1/3	Capacitor DOL	10	0.5	30	10	40	36	235	511	466	463	418	
80HD22.2	3(2.2)	3"(80)	1/3	Capacitor DOL	14	0.5	30	10	45	39	235	541	466	463	418	
80HD23.7	5(3.7)	3"(80)	3	DOL	22	0.5	30	10	-	44	235	-	496	-	418	
100HD23.7	5(3.7)	4"(100)	3	DOL	13	1.0	60	10	-	44	235	-	511	-	463	
80HD25.5	7.5(5.5)	3"(80)	3	DOL	28	0.5	30	10	-	72	286	-	610	-	550	
100HD25.5	7.5(5.5)	4"(100)	3	DOL	19	1.0	60	10	-	75	286	-	610	-	550	
150HD25.5	7.5(5.5)	6"(150)	3	DOL	12	1.5	90	10	-	78	286	-	610	-	550	
100HD27.5	10(7.5)	4"(100)	3	DOL	25.5	1.0	60	10	-	80	286	-	610	-	550	
150HD27.5	10(7.5)	6"(150)	3	DOL	17	1.5	90	10	-	81	286	-	610	-	550	
100HD211	15(11)	4"(100)	3	DOL	36	1.0	60	10	-	125	330	-	700	-	642	
100HD215	20(15)	4"(100)	3	DOL	46	1.0	60	10	-	134	330	-	700	-	642	
150HD211	15(11)	6"(150)	3	DOL	26.5	1.5	90	10	-	124	330	-	700	-	642	
150HD215	20(15)	6"(150)	3	DOL	35	1.5	90	10	-	133	330	-	700	-	642	

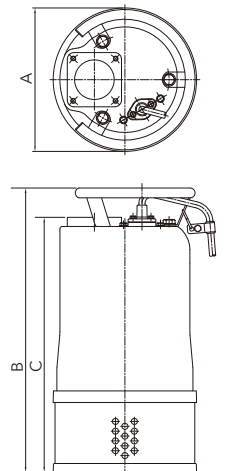





HDG 2-5HP



HDG 7.5-10HP

# HDG

## FEATURES

- Optimizing HDG series designed with hardened ductile cast iron (FCD-700) agitator, for maximum stirring and pump action for slurry applications.
- Standard accessories include: cable with an epoxy resin sealed water-resistant cable base, Auto-cut motor protector, double mechanical seals, oil seal design, and High Solid Epoxy coating.
- High efficient special impeller design in High Chrome Alloy steel (HiCrFC), with a hardness of 55 - 60 Rockwell, to stand high abrasive applications.



Open Impeller



Close Impeller



Agitator

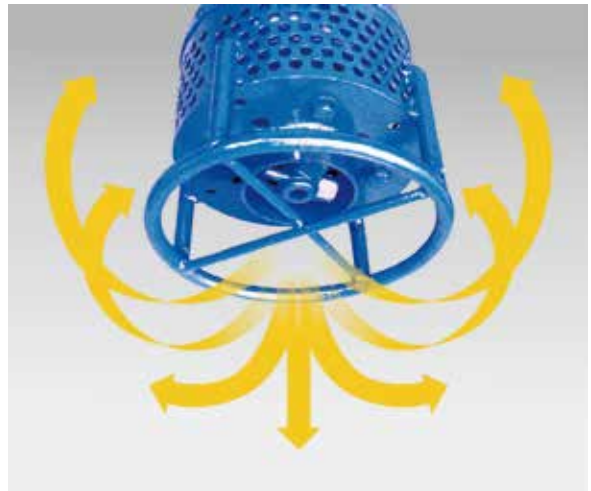

## APPLICATIONS

- Civil engineering, dewatering, tunneling, groundworks, mining, and manhole sewer.
- Industrial wastewater dewatering of fluids containing solid sediments.
- Portable use for contractors, installers, and industry.

## PRODUCT NOMENCLATURE

80	HDG	2	1.5
Discharge mm	Type	Pole	kW

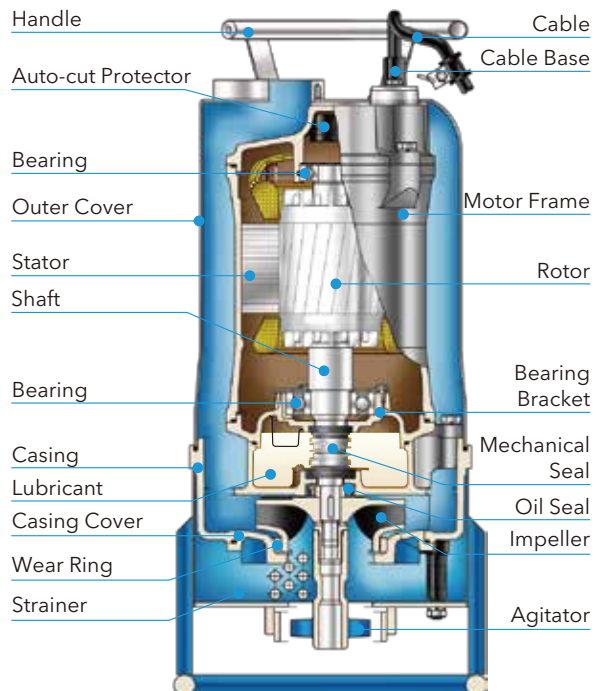

# HDG

## SUBMERSIBLE SLURRY DEWATERING PUMPS



### PERFORMANCE CURVES

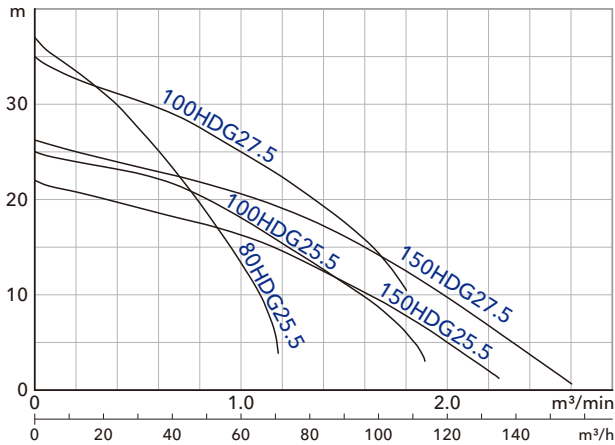
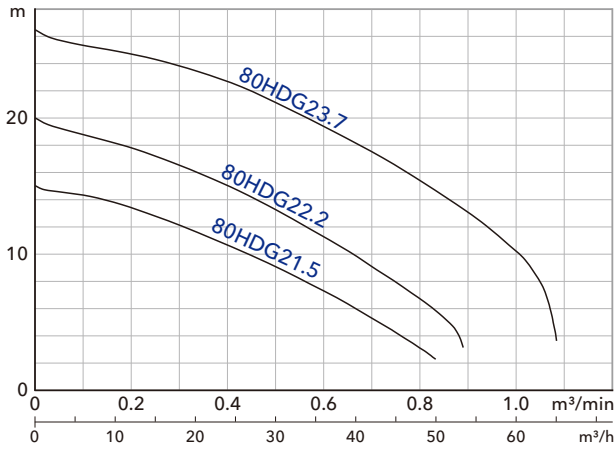

### SPECIFICATIONS

Item		Description
Limits of Use	Liquid Temp.	0~40°C (32~104°F)
	Applications	Dewatering Fluids Contain Solid Sediment
Type	Frequency	50Hz
	Motor	2P (3000rpm) • Dry Motor
	Insulation	Class F (2~5HP) • Class H (7.5~10HP)
	Protection	IP68
	Protector	Auto-cut
	Bearing	Ball type
	M.seal	Double M.seals
	Impeller	Open • Close
Material	Outer cover	SUS304 / X5CrNi18-10
	Upper Cover	FC200 / GG-20
	Motor Frame	FC200 / GG-20
	Shaft	SUS403 / X5Cr13 (2~3HP) • SUS304 / X5CrNi18-10 (5~10HP)
	M.seal	CA/CE & SiC/SiC
	Casing	FC200 / GG-20
	Impeller	HiCrFC
	Wear plate	HiCrFC (For Open)
	Wear ring	HiCrFC (For Close)
	Agitator	FCD700 / GGG-70
	Cable	VCT or H07RN-F
Optional	Pumps can be customized to fit specifications	





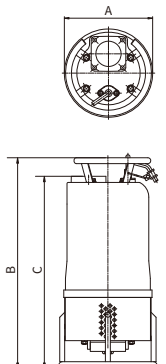

### PERFORMANCE SPECS.

※Note : Weight Without Cable & Outlet.

Model	Output HP(kW)	Discharge Inch(mm)	Phase	Start Method	Head m	Standard		Solid Passage mm	Weight kg		Dimensions mm				
						m³/min	m³/h		1Ø	3Ø	A		B		C
											1Ø	3Ø	1Ø	3Ø	
80HDG21.5	2(1.5)	3"(80)	1/3	Capacitor DOL	9	0.5	30	10	41	36	260	592	547	546	502
80HDG22.2	3(2.2)	3"(80)	1/3	Capacitor DOL	13	0.5	30	10	45	40	260	622	547	577	502
80HDG23.7	5(3.7)	3"(80)	3	DOL	21	0.5	30	10	-	45	260	-	577	-	532
80HDG25.5	7.5(5.5)	3"(80)	3	DOL	27	0.5	30	10	-	73	318	-	683	-	623
100HDG25.5	7.5(5.5)	4"(100)	3	DOL	18	1.0	60	10	-	76	318	-	683	-	623
150HDG25.5	7.5(5.5)	6"(150)	3	DOL	11	1.5	90	10	-	79	318	-	683	-	623
100HDG27.5	10(7.5)	4"(100)	3	DOL	24.5	1.0	60	10	-	81	318	-	683	-	623
150HDG27.5	10(7.5)	6"(150)	3	DOL	16	1.5	90	10	-	82	318	-	683	-	623



# OPTIONAL OUTLET SET

Output HP(kW)	Discharge inch(mm)	Lower PCD*Holes	LOH Hose Connection	LOT Male Thread Connection	LOF Flange Connection	LKF Double Flange Set	LOC Center Line Flange	LEB Elbow Sets (HD)
								
2(1.5) 5(3.7)	2"(50)	98*4	LOH2-98	LOT2-98	LOF2-120-125*98	LKF2-120*98	-	LEBX-98
	3"(80)	98*4	LOH3-98	LOT3-98	LOF3-150-160*98	LKF3-150*98	LOC3-150*98	LEBX-98
	4"(100)	98*4	LOH4-98	LOT4-98	LOF4-175-190*98	LKF4-175*98	-	LEBX-98
7.5(5.5) 10(7.5)	3"(80)	127*4	LOH3-127	LOT3-127	LOF3-150-160*127	LKF3-150*127	LOC3-150*127	-
	4"(100)	127*4	LOH4-127	LOT4-127	LOF4-175-190*127	LKF4-175*127	-	-
	6"(150)	127*4	LOH6-127	LOT6-127	LOF6-240*127	LKF6-240*127	-	-
15(11) 20(15)	4"(100)	145*4	LOH4-145	LOT4-145	-	-	LOC4-175*145	-
	6"(150)	145*4	LOH6-145	LOT6-145	-	-	LOC6-240*145	-

## PRODUCT NOMENCLATURE

LOF	4	-	175 - 190	*	98
Type	Discharge		PCD (upper flange)		PCD (lower flange)

LOH	4	-	98
Type	Discharge		PCD

※Pumps require center align could adapt with LOC sets, which can prevent center of gravity (CG) swift under pipe connection, keep dewatering in alignment with pipe arrangement.

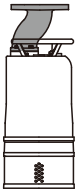

## ACCESSORIES : ADAPTER

ADTC (Adapter Connection) Pump model, can be applied with flange type adapter or check valve is an optional accessory for groundwater, deep well or wellpoint dewatering applications.



Adapter Connection (ADTC)

## OPTIONAL ADTC (ADAPTER CONNECTION) CASING

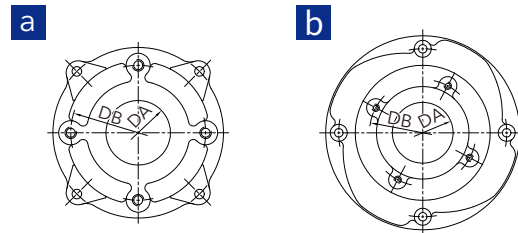



Figure	Model	mm		Bolt Size	Screw Number
		DA	DB		
a	80HD21.5/22.2/23.7	67	140	M12*25L	4
a	100HD23.7	80	150	M12*25L	4
a	100HD25.5/27.5	87	150	M12*25L	4
a	150HD25.5/27.5	97	175	M12*25L	4
b	100HD211/215	100	175	M12*30L	4
b	150HD211/215	100	175	M12*30L	4

## PRODUCT FEATURES



### Epoxy Cable Base

An epoxy resin seal cable base prevents moisture from entering the motor through the core wires.



### Double Mechanical Seals

Superior abrasion resistant mechanical seal is manufactured with silicon carbide to ensure the best seal effect.



### Auto-cut Protector

Automatic On/Off motor protector to prevent motor burn out due to high temperature and excess amperage draw. The Protector can revert when the motor temperature returns to normal.



### High Efficiency Dry Motors

All stator coils are treated with insulating varnish procedures to achieve the best insulation, efficiency and durability.

**HCP** Professionalism • Innovation • Service • Commitment  
**HCP PUMP MANUFACTURER CO., LTD.**  
 www.hcppump.com



Distributor: